

Roger Williams University

DOCS@RWU

Historic Preservation

Community Partnerships Center

2013

The Baptist Church in Warren: Rehabilitation and Preservation Report

Elizabeth Cardarelli

Valtinen Kari

Corey Pacheco

Lauren Bambara

Arnold Robinson

Community Partnerships Center, cpc@rwu.edu

Follow this and additional works at: https://docs.rwu.edu/cpc_preservation



Part of the [Historic Preservation and Conservation Commons](#)

Recommended Citation

Cardarelli, Elizabeth; Kari, Valtinen; Pacheco, Corey; Bambara, Lauren; and Robinson, Arnold, "The Baptist Church in Warren: Rehabilitation and Preservation Report" (2013). *Historic Preservation*. 11.

https://docs.rwu.edu/cpc_preservation/11

This Document is brought to you for free and open access by the Community Partnerships Center at DOCS@RWU. It has been accepted for inclusion in Historic Preservation by an authorized administrator of DOCS@RWU. For more information, please contact mwu@rwu.edu.



The Baptist Church in Warren

Rehabilitation and Preservation Report

Community Partner:
The Baptist Church in Warren

Academic Partner:
School of Architecture, Art
and Historic Preservation

Fall 2013

The Roger Williams University Community Partnerships Center

The Roger Williams University (RWU) Community Partnerships Center (CPC) provides project-based assistance to non-profit organizations, government agencies and low- and moderate-income communities in Rhode Island and Southeastern Massachusetts. Our mission is to undertake and complete projects that will benefit the local community while providing RWU students with experience in real-world projects that deepen their academic experiences.

CPC projects draw upon the skills and experience of students and faculty from RWU programs in areas such as:

- American Studies
- Architecture and Urban Design
- Business
- Community Development
- Education
- Engineering and Construction Management
- Environmental Science and Sustainability
- Finance

- Graphic Design
- Historic Preservation
- History
- Justice Studies
- Law
- Marketing and Communications
- Political Science
- Psychology
- Public Administration
- Public Relations
- Sustainable Studies
- Visual Arts and Digital Media
- Writing Studies

Community partnerships broaden and deepen the academic experiences of RWU students by allowing them to work on real-world projects, through curriculum-based and service-learning opportunities collaborating with non-profit and community leaders as they seek to achieve their missions. The services provided by the CPC would normally not be available to these organizations due to their cost and/or diverse needs.

CPC Project Disclaimer: The reader shall understand the following in regards to this project report:

1. The Project is being undertaken in the public interest.
2. The deliverables generated hereunder are intended to provide conceptual information only to assist design and planning and such are not intended, nor should they be used, for construction or other project implementation. Furthermore, professional and/or other services may be needed to ultimately implement the desired goals of the public in ownership of the project served.
3. The parties understand, agree and acknowledge that the deliverables being provided hereunder are being performed by students who are not licensed and/or otherwise certified as professionals. Neither RWU nor the CPC makes any warranties or guarantees ex-

pressed or implied, regarding the deliverables provided pursuant to this Agreement and the quality thereof, and Sponsor should not rely on the assistance as constituting professional advice. RWU, the CPC, the faculty mentor, and the students involved are not covered by professional liability insurance.

4. Neither RWU, the CPC, the faculty mentor, nor the students involved assume responsibility or liability for the deliverables provided hereunder or for any subsequent use by sponsor or other party and Sponsor agrees to indemnify and hold harmless RWU, the Center, the Faculty Mentor, and the Center's student against any and all claims arising out of Sponsor's utilization, sale, or transfer of deliverables provided under this Agreement.

Community Partnerships Center
Roger Williams University
One Old Ferry Road
Bristol, RI 02809
cpc@rwu.edu
<http://cpc.rwu.edu>



The church's bell, recast in 1906 by Meneely and Company of New York, was originally cast in 1800 by Paul Revere.

Table of Contents

Introduction and Methodology	4
History and Significance.....	5
Site Conditions and Constraints.....	7
Existing Conditions.....	8
Rehabilitation Plan.....	16
Conclusion.....	30

December 2013

Team Members: Elizabeth Cardarelli | Valtinen Kari | Corey Pacheco

Drafting Support provided by Lauren Bombara

HP 681 - Historic Rehabilitation | Professor Arnold Robinson

HP 384 - Preservation Planning Workshop | Professor Arnold Robinson

Introduction and Methodology

The research presented in this report was done in fulfillment of course requirements for HP 681 Historic Rehabilitation Workshop and HP 384 Preservation Planning Workshop in the Roger Williams University (RWU) Historic Preservation program. The work was completed in coordination with the RWU Community Partnerships Center.

The primary focus of this project was for the student team to suggest a rehabilitation plan for the Baptist Church in Warren, Rhode Island. Students were tasked with inspecting the church and advising the staff on preservation priorities for

the site along with suggested rehabilitation methods that would be in line with requirements for the National Historic Register.

The outcomes presented in this report are the result of work completed from September to December 2013. This report includes an existing conditions assessment, photographs to identify conditions of individual elements that comprise the church, and recommendations for rehabilitation of the building.

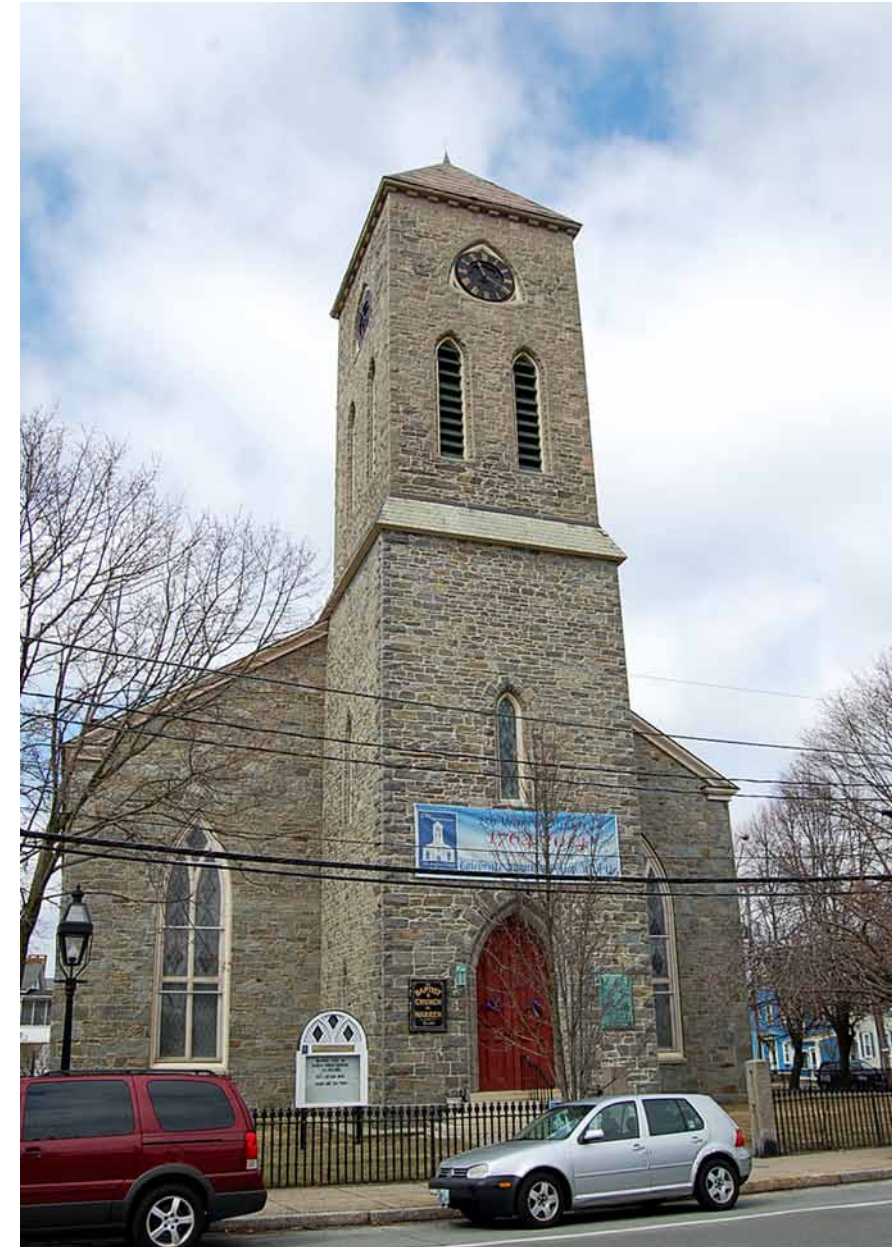

Facade of The Baptist Church in Warren.

History and Significance

History of the Baptist Church in Warren

The Baptist Church in Warren is located at 407 Main Street in Warren, Rhode Island. This was the original site of Brown University (then called Rhode Island College) in 1764. The church itself went through three buildings: a small meeting house from 1764-1778, which burned down; a larger wooden building between 1784-1884; and the current stone structure in which the congregation resides.

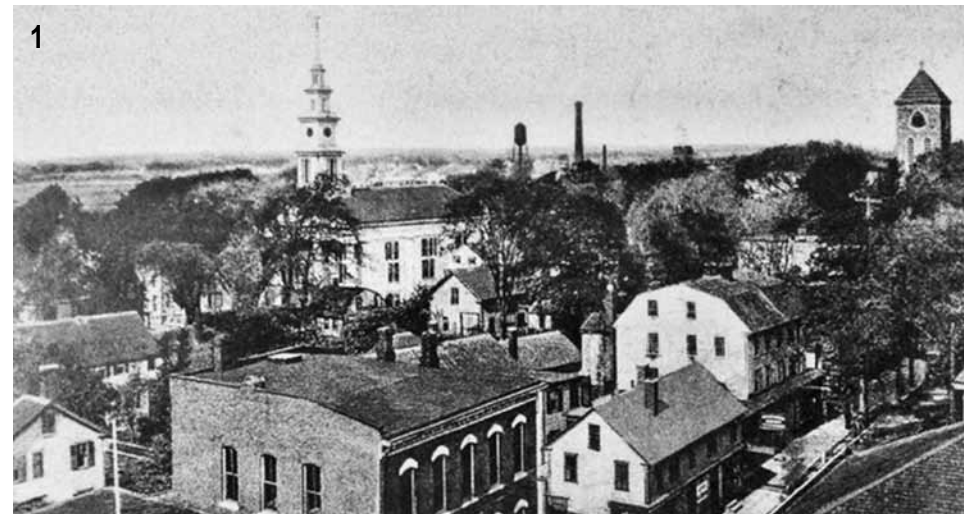

1

The current edifice was designed in the Gothic style and was erected in 1844 to replace the former wooden church. There was a partial fire in 1872, the evidence of which was discovered during renovations to the kitchen, circa 1939.

The vestries were added to the structure in 1904, and in 1906 the bell, originally cast by Paul Revere in 1800, was recast by Meneely and Company from Waterliet, NY. In 1913, the chancel, including the stained glass windows, were added to the current edifice.

Historical and Architectural Significance

The Baptist Church in Warren currently exists within the Warren Waterfront Historic District. The structure was designed by noted architect Russell Warren, and is integral to the overall character of the town. It contributes to the rural New England small town feeling in which the community of Warren takes great pride.

The church itself is in good condition and serves as an excellent representation of the mid-19th century New England Gothic style church with medieval themes. The Baptist Church in Warren is still in operation, and the continued maintenance of the building has risen in importance to the congregation who is looking to increase its prominence within the community.

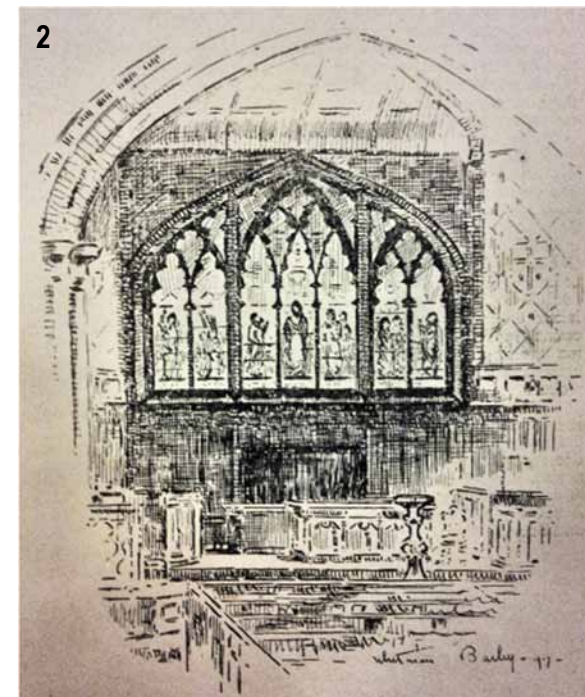

2

1. Photo found in "250th Anniversary: 1747-1997" Warren Skyline. Date unknown.

2. Photo found in the "175th Anniversary of The Baptist Church in Warren" Pamphlet 1939. Chancel drawing, circa 1917.

When the Warren Waterfront Historic District went through the nomination process for the National Register of Historic Places, the following architectural description was written for the Baptist Church:

“A stalwart, severe Gothic Revival-disguised coursed-roughed-granite-ashlar church, set well back from the street with its narrow gable end and square-plan tower facing the street. The 4 story tower rises in two stages: the lower stage has the principal double-leaf entrance within a recessed lancet arch below a diamond-pane narrow-lancet-arch window; the 2nd stage culminates in a pent roof that circumscribes the tower just above the ridge line of the main block, and in the second stage area a pair of narrow-lancet-arch louvered windows below a clock set within a

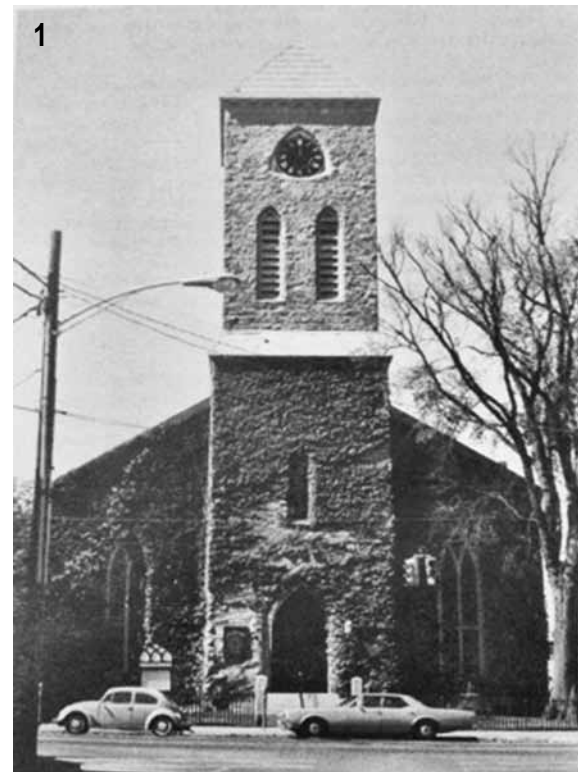

lancet-arch triangle; a modillion cornice below a striped-slate pyramidal roof (replacing a crenellated cap lost to storm damage) caps the tower. The simple main block has tall lancet-arch windows, 2 on the west elevation... Warren Baptist Church employs the Greek Revival proportion and sobriety with which [Russell Warren] was so familiar. The Church has a commanding presence on the street, especially because of the long view corridor toward it from the east along Market Street, and its tower is an important eminence on the Warren skyline from a distance on land or water.”

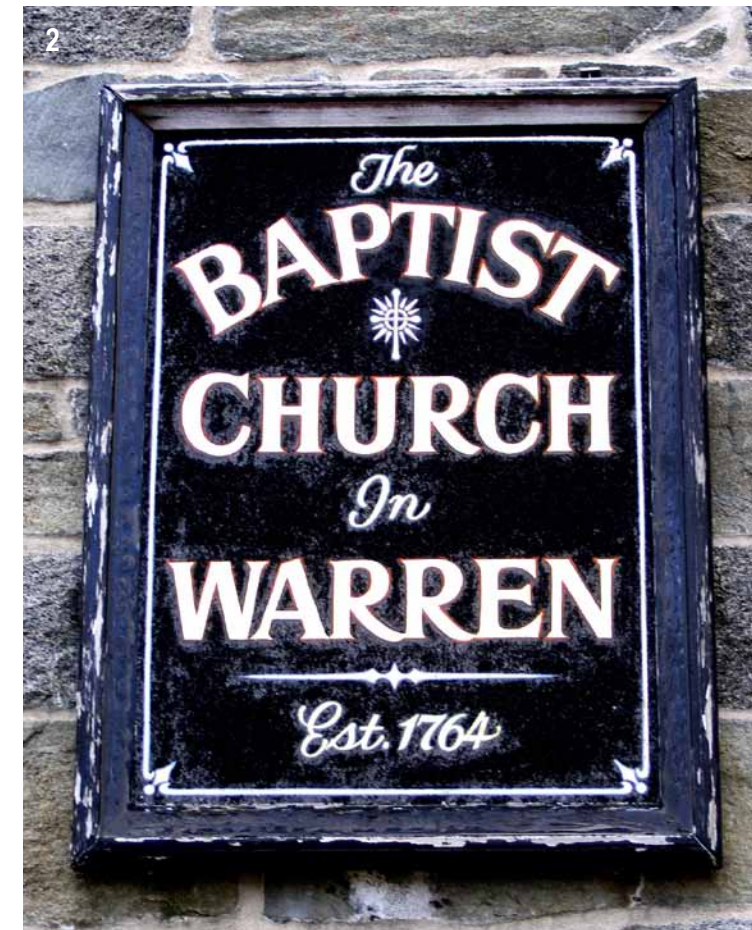

1. Photo Found in “Warren, RI Preservation Report” by the Historical Preservation Commission, 1970.
2. Signage on church facade.

Site Conditions and Constraints

The site is constrained by its location on Main Street in Warren. It is located on the corner of Main Street and Miller Street at a very busy stop-light. Main Street (Route 114) is also a very busy road and intersection.

The property is further constrained by fencing. On the east and north boundaries, a cast iron fence outlines the property's borders. On the southern boundary, the neighbors have a white picket fence.

Regulatory Requirements

The Baptist Church in Warren is located in the Warren Waterfront Historic National Register District. Warren also has a Voluntary Historic District. Both the National Register Nomination and the Voluntary Historic District have regula-

tions which pertain to changes to the exterior view shed of the building. Exterior work on this project will need to abide by the State of Rhode Island and the Providence Plantations Rehabilitation Code for existing buildings and structures and the Town of Warren Department of Building and Zoning. Exterior work done on a voluntary basis, according to the Warren Voluntary Historic District guidelines, will qualify for a 20% tax credit. The Baptist Church in Warren does not meet the requirements for the local and state tax credit.



1. The church's location on Main Street in Warren.

2. The property is constrained by a cast iron fence on two sides and a white picket fence on the southern side.

Existing Conditions

The Conditions Assessment was based on visual inspections. No invasive or destructive testing was utilized to investigate material conditions. The assessment will provide information for suitable cost estimates and help finalize the scope of work. A more detailed review of certain elements will be required when the scope is finalized. The assessment will provide a platform for recommendations that will finalize cost estimates and help the client prioritize work.

Conditions Terminology

Excellent condition: Element is in new or equivalent condition. No work needed other than routine maintenance.

Good condition: Element is performing its intended function or is otherwise serviceable, although it may show signs of wear. No repair required other than routine maintenance.

Fair condition: Element requires work, usually minor, to better perform its intended function, bring to a maintainable state or return to a condition resembling its historic appearance.

Poor condition: Major work needed for element to perform its intended function or to bring item to a maintainable state.

Original: Dates to the period of initial construction.

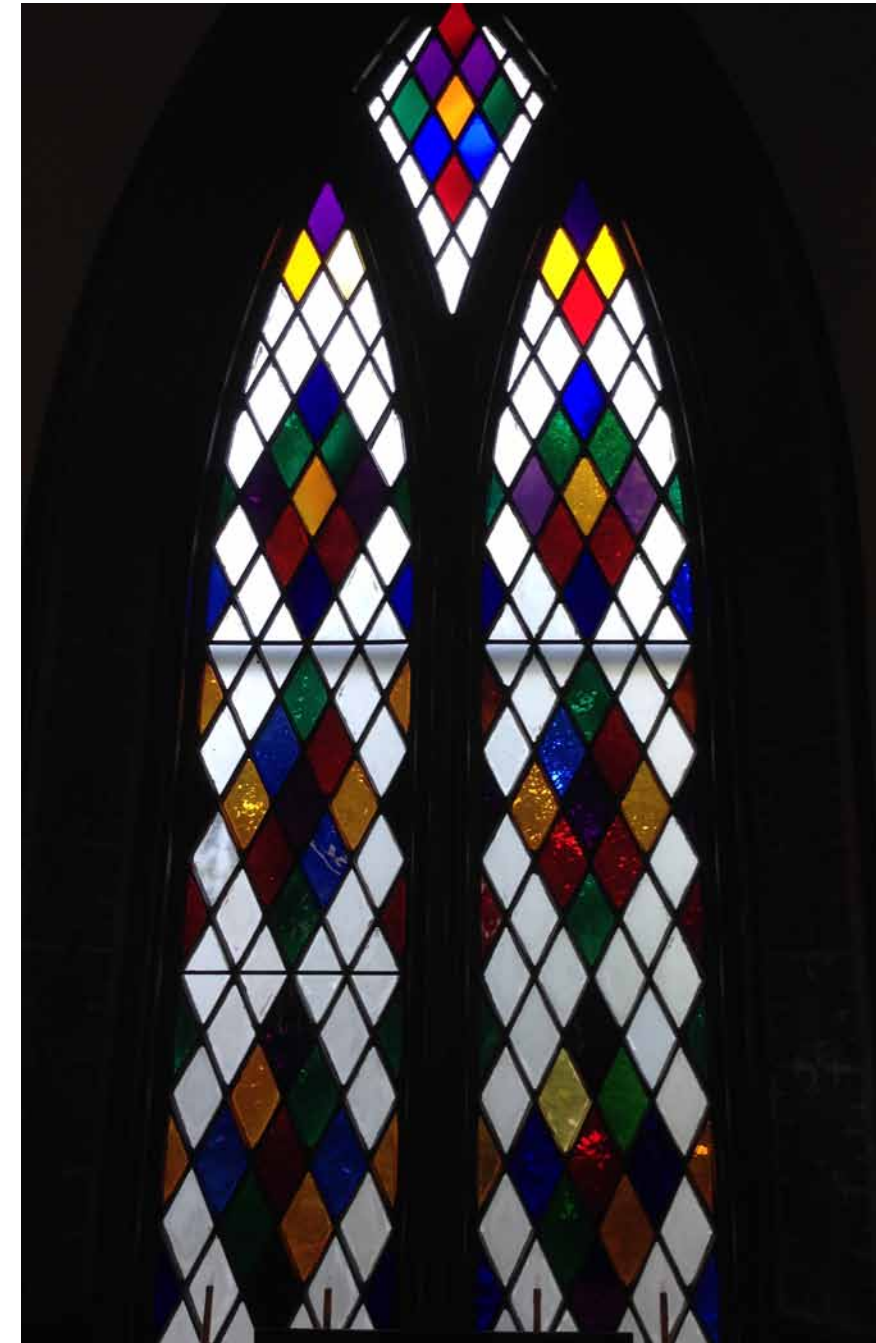

A lancet-arched, diamond-paned window of The Baptist Church in Warren.

Existing Conditions

Exterior Assessment

Roofing

The majority of the roof is covered in grey slate, however the bayed section of the western exposure—which is the interior vestry—is covered in three tab asphalt shingles.



Chancel Roof

The chancel's roofing is currently asphalt shingles and was replaced within the last ten years. This change was made in order to prevent the roof from leaking water into the building. This roof is in good condition; there was no structural damage to rafters and the attic joists because of water leakage.

Tower Roof

The roof covering the church's tower is bi-colored with grey and red slate forming a striped pattern. Overall, the roof is in fair condition, however, the slate shingled areas are in need of repair. Many slates are missing or hanging by one hanger. This is a failure of the hangers, which only last about a hundred years. These hangers are probably made of brass or copper, since they were the leading hangers of the 1840's. The copper ridge cap looks to be in fair condition, however, after 100 years of service, the roof is showing inevitable signs of age. The framing for the tower roof is in good condition and shows no visible signs of water damage or rot associated with insects or environmental effects.

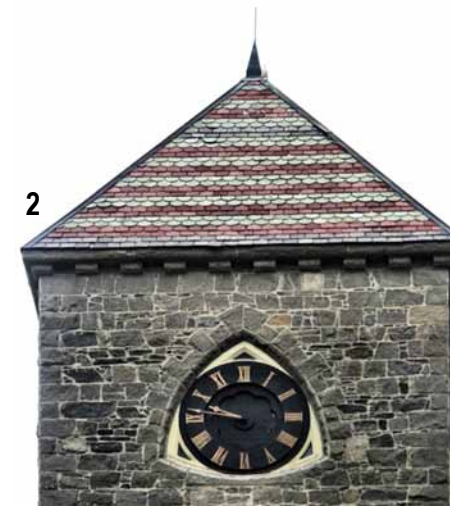

Midpoint on the tower, a pent roof projects from the structure. The pent roof is covered in green slate with slates sliding out of position. Darker slates are mixed in with the dominant green, suggesting prior repair. The flashing of the pent roof into the granite structure is in fair condition.

Main Church Roof

The gable roof of the main structure is covered in green slate. Overall, the main roof is in poor condition. The existing slate roof was installed over a wooden shingled roof. The condition of the wooden shingles is unknown and could be a cause of the roof's poor condition. As with the tower roof, slates are sliding out of position, which could be caused by failing ferrous fasteners. Certain slates are exhibiting breakage, which could be the result of impurities in the slate. Numerous dark-colored slates show prior maintenance; yet there are missing slates throughout. The copper ridge cap is in good condition. Recently, Renaissance Roofing of Woonsocket, Rhode Island replaced over 400 slate tiles on the main roof.

1. A view of the roof from the tower window. The dark patches are missing slate shingles.
2. The tower roof, showing the red and grey slate striped pattern of the tiles.

Drainage

The only existing gutter system is at the rear, western elevation of the church. There is no internal draining system, which was common with Gothic churches of this time period. There was no way for the team to determine what the gutter system at the western elevation looked like above the cornice. Currently there are just two downspouts that can be seen. While the slate roof and roof angle encourage the draining of water, the building itself is not conducive to water drainage. Grading around the church is flat, and the foundation itself is surrounded by flat masonry. While there are holes at the base of the building that allow for water runoff, there is evidence that rainwater gathers at the base of the church, resulting in organic growth along the northern elevation.

Cornice

The cornice is composed of a single solid wooden Grecian ovolo profile that is terminated by a large bead at the base. The cornice wood is in good condition with the exception of the paint finish, which is flaking throughout the perimeter of the cornice.

Masonry

The church is composed of a monolithic, load-bearing, granite-ashlar block. There is no differentiation between the exterior wall and foundation. There is green organic growth along the lower portion of the south and north elevations. Under the windows on the western façade, there is a crack forming in the mortar. Overall the exterior granite and mortar pointing are in good condition. The granite exterior recently underwent restoration.



The masonry along the west elevation appears to be in good condition, displaying no structural concerns or material pathologies. There is some staining of the stone due to the bleeding of the rusted iron fittings designed to support lighting along the church's rear, but there appears to be no other damage other than aesthetic from this.



1. Drainage holes along the base of the north facade show mildew growth from water damage.

2. Paint failure on cornice.

Windows

The church exhibits tall, lancet-arched, diamond-paned windows throughout: two on the façade on the western elevation, five each on the northern and southern elevations, and two on the eastern elevation. These windows are in fair condition, protected by custom fabricated aluminum storm windows. The storm windows are in good condition, with some fasteners exhibiting rust. The exterior side of the windows has issues with paint cracking and



alligating. The bond between layers has broken due to inter-coat paint failure. This allows exterior moisture to penetrate the surface cracks, causing the wood to swell and deeper cracking to take place.

The window glazing is failing. This process has become exacerbated due to the storm windows. The storm windows are not properly ventilated, causing a micro climate within the space between the storm window and the wooden window. This micro climate is causing the paint and glazing to peel away.

Doors

The west façade contains double-leaf, lancet-arched entrance doors, which are in good condition and working order. The north façade contains a handicapped accessible entrance that leads into the basement. The doors are in good condition and in good working order minus some paint issues at the bottom. The door located on the east façade leads to the boiler room, hot water heater and electrical services. This door is in good condition and working order.



1. The northeast window, located on the east façade, has an opening that traps moisture in the cavity between the window and storm window.

2. The doors on the northern entrance exhibit paint peeling and rot at the bottom.

Existing Conditions

Interior Assessment

Overview

The interior of the church's sanctuary is painted white and has many medieval influences that add to the Gothic Revival style including Gothic arches, trefoils and quatrefoils. There are many finishes present in the room; gold, silver and aluminum leaf were used in the wall murals; and canvas covered in gold leafing is seen on the ceiling above the vestry and on the western elevation. Murals surround each of the windows along the north and south elevations, the insides of the Gothic arches, and the walls above the vestry. The wood in the room is a faux finish. Paneling is pine that has been painted to look like mahogany, using a dragging and combing technique. The panels in the doors are canvas, which has been painted to look like mahogany using the same technique. In many places, these finishes are damaged.

A water leak from the faulty roof has caused damage to a mural above the vestry on the western elevation. The mural has peeled away from the plaster and the faux wood finish has become stained. Cracking and peeling of the murals

around the windows along the northern and southern elevations has also occurred. Cracks in the paint and plaster of the walls are also visible. This could be due to settling of the foundation. These cracks are especially noticeable around windows on the northern and southern elevations.

Attic: Main Structure

The exposed exterior roof and sanctuary roof structure is rough-sawn dimensional timber. This structure replaced the original 1844 roof after a fire. A well-maintained mural and a plaster cornice are still in place where the original roof was located. The attic structure is in good condition.

Ceiling

The ceiling is vaulted, painted plaster with wood ribbing. This is the second ceiling. The original ceiling was much higher and had a stenciled trim where the wall met the ceiling. The ceiling is in good condition with only a few areas that need to be checked for water damage and need repainting.



Sanctuary of The Baptist Church in Warren.

Tower Stairways

Access to the tower is through a door in the sanctuary's balcony. The tower is comprised of exposed masonry walls and staircases that lead to the bell room and clock gears. The first staircase is 2'6" wide. The second staircase, which leads to the second level, is only 1'1" wide. The staircase



and ladders, although appearing serviceable, are narrow, cramped and unpleasant for the workers at the church. The exposed masonry allows for patching to be done to fix cracks in the mortar. There is a prominent patch under the east window.

Sanctuary Roof

The sanctuary roof is made up of thin wood composite sheet goods, most likely beaverboard. There are certain areas of the roof that exhibit damage or staining. Overall the sanctuary roof is in good condition.

Sanctuary Plaster

Overall the plaster in the sanctuary is in good condition, however there are a few sections throughout that are deteriorating or cracking, especially in the northwest and northeast corner of the building. The chancel also has plaster issues due to the roof leak. Overall, there are no sections where the plaster is completely detaching from the substrate.

Sanctuary Paint: Wall

The paint in the sanctuary varies between a solid white color, a decorative gold leaf paint and a faux wood grain painting technique. There are sections

of white field paint that are cracking. Cracking happens when paint that is several layers thick becomes excessively hard and brittle and can no longer expand and contract. Overall the field paint is in good condition.

Sanctuary Paint: Decorative

The decorative paint that accents the lancet arches throughout is in good condition. However, the paint on the lower portion of the lancet arch of the windows is deteriorating. The decorative paint in the chancel is in fair condition. The paint in the chancel has suffered moisture damage from a roof leak that has since been repaired. The paint and plaster areas that are damaged have not been repaired.

Sanctuary Paint: Faux Wood Graining

Faux wood graining can be found throughout the sanctuary on doors, door casings, pews and wood paneling. On the mezzanine, overlooking the sanctuary, the wood graining is applied on plaster to mimic wainscoting. Sections of the wood graining show failure, especially in areas applied to the plaster.



1. Narrow stairway to the bell tower, accessed through a door in the sanctuary's balcony.
2. Cracked plaster walls in the sanctuary.
3. Faux wood graining shows failure throughout the church.

Woodwork: Chancel

The finish to the wood paneling in the chancel has suffered water damage. There is not noticeable damage to the structure of the wood. Overall the wood in the chancel is in good condition.

Woodwork: Sanctuary

The condition of the doors, casings, pews and woodwork throughout the sanctuary is good. There is no noticeable damage that would require repair or impair the function of the element.

Windows: Leaded Stained Glass

There is leaded glass throughout the sanctuary. It is found on the doors leading into the sanctuary from the front entrance. It is also found in a wooden partition separating the front entry into the sanctuary. The sagging of the lead and glass is an indication that the structural integrity of the lead support is beginning to fail, but the lead came has not failed to the point of breakage or dislodging the glass. On the western and eastern elevation, the stained glass windows are in need of re-caming.

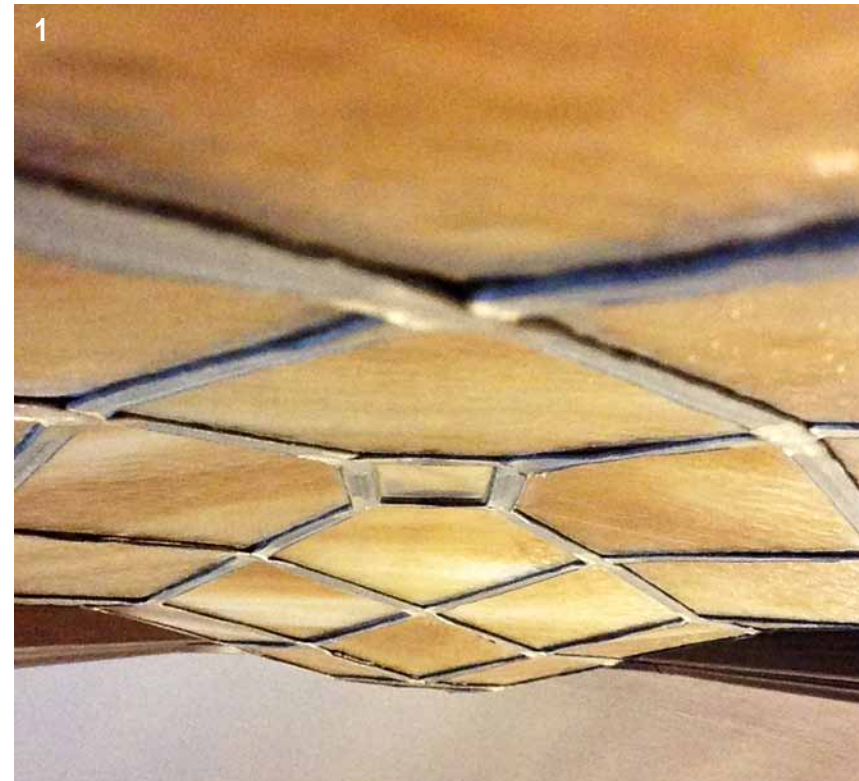

Windows: Chancel Stained Glass

The stained glass in the chancel is in good condition. There is no noticeable damage or sagging to the lead came and glass.

Windows: Lancet Windows

The overall condition of the interior side of the wooden structure is good. The paint surface of the windows is in fair condition, with areas ranging from stable to cracking to peeling.

Floor Finishes

The carpeting in the main sanctuary is heavily stained by water damage with sections worn through to the backing. The finishes throughout the rest of the building are all stable and do not require any necessary replacement at this time.



1. A pronounced view of the stained glass bowing of the doors leading into the sanctuary.
2. The carpet shows signs of water damage.

Systems: Boiler

The heating system is a boiler that was installed in 1993. The age of the system is showing. The vent for the boiler is exhausted through an old coal furnace outlet covered in asbestos. The boiler warms the basement, but does not have the duct-work infrastructure to warm the sanctuary.

Systems: Electrical

The electrical panel was replaced in 2011, but the wiring was not. For the most part, it still remains knob and tube. The electrical fixtures throughout the church and sanctuary are mostly original to when electricity was introduced to the building and are in good condition.

Systems: Plumbing

Plumbing throughout the building is older and not water efficient. There are three bathrooms; none are handicapped accessible. The plumbing fixtures are in good working condition. The hot water tank was replaced within the last five years and is in good working order.



Systems: Fire Protection

There is a smoke detector and fire alarm system throughout the building, however the building does not have a sprinkler system.

Site Conditions: Location

The church is located on a busy commercial stretch of Route 114 in Warren, Rhode Island. The site is easily accessible by automobile and public transit.

Site Conditions: Cast Iron Fencing

Skirting the perimeter of the church property on Main Street and Miller Street is a decorative cast iron fence. Overall the fence is in fair condition. There are broken cast iron posts and some issues with the protective finish. The granite base has shifted because of freeze/thaw cycles, which have upset the balance of the fencing.

Accessibility

The building is accessible by the northwest from the parking lot on Miller Street. The stair from the basement to the sanctuary main floor is handicap accessible. The bathrooms are currently inaccessible. All changes must abide by State of Rhode Island and Providence Plantations Rehabilitation Code for existing buildings and structures – Chapter 10 Accessibility – and the Town of Warren Department of Building and Zoning Accessibility must meet the 2010 ADA Standards for Accessible Design.



1. Current boiler system.

2. Cast iron fence exhibits missing and broken posts.

Rehabilitation Plan

Exterior

Main Roof and Tower Roof Division 07: Thermal and Moisture Protection

07 31 26 Slate Shingles

1.1 Existing Conditions

The gable roof of the main structure is covered in “sea green” slate. The main roof is in poor condition; the existing slate roof was installed over a wooden shingled roof. The condition of the wooden shingles is unknown and could be the cause of the roof’s poor condition. Slates are sliding out of position, which could be caused by failing ferrous fasteners. Certain slates exhibit breakage and could be the result of impurities in the slate. Currently the roof is being repaired. Around 1400 slate tiles have been replaced. The tower roof is in fair condition and is covered with alternating courses of scalloped “sea green” and rectangular “unfading red” slate. Some slates are sliding out of position.

The rehabilitation method explained herein is based on the current methods being employed by the roofing contractor.



1.2 Rehabilitation Methods

- **1.2.1** Replace broken, cracked and missing slates with new slate material. New slate should match the size, shape, texture and weathered color of old slate. Assess the condition of slates sliding out of position; salvage sound undamaged slate and re-hang with copper fasteners.
- **1.2.2** Slide new slate into place and hold in position with one nail inserted through the vertical joint between the slates in the course above and approximately one inch below the tail of the slate two courses above. To prevent water penetration through the newly created nail hole, a piece of copper with a friction

fit, measuring roughly 3” (7.5 cm) in width and 8” (20 cm) in length, is slid lengthwise under the joint between the two slates located directly above the new slate and over the nail.

- **1.2.3** Alternate methods for securing the replacement slate include the use of metal hooks, clips and straps that are bent over the tail end of the slate.
- **1.2.4** The application of roofing mastic or sealants to damaged slates should not be considered a viable repair alternative because these materials, though effective at first, will eventually harden and crack, thereby allowing water to enter.
- **1.2.5** Sheathing should be checked for rotted areas. Plywood is generally not a good replacement material for deteriorated wood sheathing due to the relative difficulty of driving a nail through it (the bounce produced can loosen adjacent slates). Instead, new wood boards of similar width and thickness to those being replaced should be used.
- **1.2.6** All materials and shop drawings required for work in this section shall be subject to approval by preservation consultant or architect based on submittal of product information, samples and supporting material.¹

The main church roof consists of green slate shingles covering wooden shingles.

07 71 23 Manufactured Gutters and Downspouts

1.1 Existing Conditions:

A gutter and drainage system exists only on the west elevation (chancel addition). The gutter system on the south elevation is built in behind the wooden cornice and should be replicated throughout.

1.2 New Gutter and Downspout Installation:

- **1.2.1** Mimic construction detail of current gutter system on south elevation. This may include but is not limited to the following:
- **1.2.2** Remove first five courses of slate above cornice. Remove sheathing as needed to accommodate new gutter system and repair or reinforce rafter tails.
- **1.2.3** Construct and fabricate a gutter system behind cornice detail. The structure of the gutter shall be made of wood and lined with copper.
- **1.2.4** Downspouts shall be made of copper. Drainage from downspouts shall be properly diverted into the ground and away from the building.
- **1.2.5** Acceptable installation of copper gutter system or equal: <http://www.copper.org/>



[applications/architecture/arch_dhb/archdetails/gutters_downspouts/gutter_linings.html](http://www.copper.org/applications/architecture/arch_dhb/archdetails/gutters_downspouts/gutter_linings.html)

- **1.2.6** All materials and shop drawings required for work in this section shall be subject to approval by preservation consultant or architect based on submittal of product information, samples and supporting material.²

07 00 00 Thermal and Moisture Protection

07 11 00 Damp-proofing

1.1 Existing Conditions: Along the north and south elevations, an asphalt skirt runs the perimeter of the building. While the original intent of this feature is uncertain, it is presumed to have been installed as a water mitigation measure. To the contrary, this skirt instead retains water and causes splash-back.

1.2 Recommendations: A French drain should replace the current asphalt skirt in order to properly redirect water flow to the west of the property.

- **1.2.1** The asphalt skirt should be removed.
- **1.2.2** A ditch should be dug along the same area at ten inches wide and twenty-four inches deep.
- **1.2.3** Gravel should line the bottom two inches of the ditch.
- **1.2.4** Perforated PVC pipe of eight-inch diameter should be installed.
- **1.2.5** Landscape fabric should be placed over the pipe to prevent blockages.

- **1.2.6** The rest of the ditch should be filled with gravel up to two inches below grade.
- **1.2.7** The remaining two inches should be filled in with dirt.

07 72 53 Snow Guards

1.1 Existing Conditions:

Currently there are no snow guards on the tower and main roof.

1.2 Rehabilitation Plan:

- **1.2.1** Install new snow guards in accordance with manufacture specification, instruction and warranty.
- **1.2.2** Acceptable manufacturer: <http://www.alpinesnowguards.com/our-products> or equal.
- **1.2.3** Snow guards are generally placed first three rows 24 inches on center with the middle row staggered 12 inches starting at the outer wall or outer-most roof support. The remaining snow guards are evenly spaced to the top 10 feet of the rafter. The top 10 feet of rafter does not require snow guards except in extreme snow load areas.
- **1.2.4** All materials and shop drawings required for work in this section shall be subject to approval by preservation consultant or architect based on submittal of product information, samples and supporting material.³

Downspout on the southeast corner of the west facade.

Cornice Rehabilitation Plan Division 06: Wood, Plastics and Composites

06 01 40 Maintenance of Architectural Woodwork

1.1 Existing Conditions:

The cornice is in good condition with no notable deficiencies to the structure of the wood. The protective layer of paint on the cornice is failing and requires preparation and repainting.

09 01 90.52 Maintenance Repainting

1.2 Rehabilitation Method for Cornice Paint:

- 1.2.1 Flaking, cracking, blistering, peeling or otherwise deteriorated paint shall be removed by hand. Paint shall be removed to bare substrate or first sound paint layer. After cleaning and removal of deteriorated paint, edges of remaining paint shall be feathered and sanded smooth.

- 1.2.2 Provide paint that matches existing color. Provide alkyd-based paint as a primer coat for bare wood where necessary. Utilize latex based paint for subsequent finish coats in accordance with manufacturer's recommendations. Allow dry time per manufacturer instructions.
- 1.2.3 Acceptable manufacturer for alkyd based primer: Benjamin Moore Fresh Start Moor white Penetrating Alkyd Primer (100) or equal: <http://www.benjaminmoore.com/en-us/for-architects-and-designers/paint-products/fresh-start-premium-primers?>
- 1.2.4 Acceptable manufacturer for exterior latex based finish paint: Benjamin Moore Aura Waterborne Exterior Paint or equal: <http://www.benjaminmoore.com/en-us/for-architects-and-designers/paint-products/aura-waterborne-exterior-paint?>
- 1.2.5 All materials and shop drawings required for work in this section shall be subject to approval by preservation consultant or architect based on submittal of product information, samples and supporting material.⁴

Window Rehabilitation Plan Division 08: Openings

08 01 52.93 Historic Treatment of Wood Windows

1.1 Existing Conditions:

The windows are in fair condition, meaning little structural deficiencies exist but there is widespread paint and glazing failure throughout. Some portion of the windows will need repair, and some glass will need to be replaced. The windows are currently unoperable and painted shut. The owner would like to open the windows.

1.2 Rehabilitation Methods:

Removal of Sash:

- 1.2.1 Record location of each sash prior to removal to ensure sash is reinstalled in original location.
- 1.2.6 Record location of all window stops and trim work that will be removed in order to take out windows from openings.

Carefully remove all window stops and trim work in order to remove sash, and catalogue with window.

- 1.2.7 Carefully wrap and protect all windows in packing blankets for removal from the job site.
- 1.2.8 Immediately after removing sash, install temporary plywood covering in window openings, sealing as necessary to obtain a weather tight installation.
- 1.2.9 Do not secure fasteners into existing window frames or surrounding construction when installing temporary window protection.

Paint failure around the windows due to moisture exposure.



- **1.2.10** Thoroughly vacuum all areas where windows have been removed with a HEPA certified vacuum cleaner.

Removal of Hardware:

- **1.2.11** Record location of hardware that is to be removed, number and document the location of each piece of hardware. Determine if hardware needs replacement. Remove hardware.
- **1.2.12** Clean hardware that does not need repair without damaging the finish. Store in appropriately labeled containers until reinstallation.
- **1.2.13** Reinstall hardware back to original location according to number and window inventory. Replacement fasteners to match original fasteners.
- **1.2.14** Provide new hardware to match existing original hardware, custom-made if necessary, in locations where existing is missing or damaged.
- **1.2.15** Acceptable manufacturer: Al Bar Wilmette Platers, 127 Green Bay Road, Wilmette Illinois, 60091 or equal: <http://www.albarwilmette.com> or equal. Acceptable Manufacturer: Brandywine Forge 201 North 4th Avenue #5 Royersford, PA, 19468 <http://www.bvforge.com>.

Glass Removal and Reinstallation:

- **1.2.16** Record location of glass to be removed. Number and document the location of each piece of glass. Determine if glass needs replacement.
- **1.2.17** Place window in steam stripper according to manufacturer's specifications in order to remove glazing. Remove glazing with hand tools. For crown glass, utilize heat gun and heat shield to manually remove glazing.
- **1.2.18** Existing glass to be reused. Clean glass removed from windows and store in appropriately labeled and protective containers until reinstallation.
- **1.2.19** Clean and sand all glazing rabbets of previous glazing and paint.
- **1.2.20** Prime glass rabbets with latex or oil-based primer. Allow appropriate dry time.
- **1.2.21** Install full bed of glazing putty, reinstall glass back to original location according to number and window inventory, and hold in place with glazing points. Acceptable manufacturer for glazing putty: SarcoSeal Multi Glaze type "M" for wood sash or equal. <http://smithrestorationsash.com/glazingputty.html>
- **1.2.22** Apply glazing putty with enough pressure to eliminate voids and to ensure bond to glass and wood substrate. Tool smooth and make sure glazing putty does not extend past

interior muntin profile; glazing compound shall not be visible from interior

- **1.2.23** Allow glazing compound to skin over before finish painting.

Paint Removal:

- **1.2.24** Flaking, cracking, blistering, peeling or otherwise deteriorated paint shall be removed by hand scraper to bare substrate or first sound paint layer. After cleaning and removal of deteriorated paint, remaining paint shall be feather-edged and sanded smooth.

Repairs to Wood Sash:

- **1.2.25** Dutchman repair done with in-kind material as appropriate; ensure sound existing material is saved. At completion of work, all frames and sash must be free of rotted and deteriorated wood and true to original profiles. All joints to be well glued and pinned. Acceptable manufacturer: Titebond Woodworking Glues or equal: http://www.titebond.com/woodworking_glues.aspx
- **1.2.26** Repair sash and frames using epoxy consolidant when Dutchman repair is deemed unnecessary. Acceptable manufacturer: West System Epoxy or equal. <http://www.westsystem.com/ss/>

Finish Paint:

- **1.2.27** Paint color should match existing color. An alkyd-based paint should be used as a primer coat for unfinished or stripped wood where necessary. Latex based paint should be used for subsequent finish coats in accordance with manufacturer's recommendations. Allow dry time per manufacture instructions.
- **1.2.28** Acceptable manufacturer for alkyd based primer: Benjamin Moore Fresh Start Moor white Penetrating Alkyd Primer (100) or equal: <http://www.benjaminmoore.com/en-us/for-architects-and-designers/paint-products/fresh-start-premium-primers?>

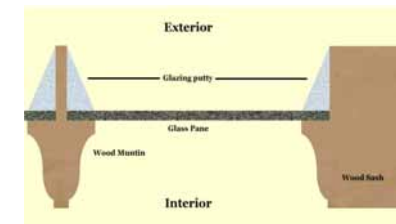

Window repair requires removing hardware, scraping paint by hand and re-glazing the glass.

- **1.2.29** Acceptable manufacturer for exterior latex based finish paint: Benjamin Moore Aura Waterborne Exterior Paint or equal: <http://www.benjaminmoore.com/en-us/for-architects-and-designers/paint-products/aura-waterborne-exterior-paint?>
- **1.2.30** Acceptable manufacturer for interior latex based finish paint: Benjamin Moore Aura Waterborne Interior Paint or equal: <http://www.benjaminmoore.com/en-us/for-architects-and-designers/paint-products/aura-waterborne-interior-paint?>

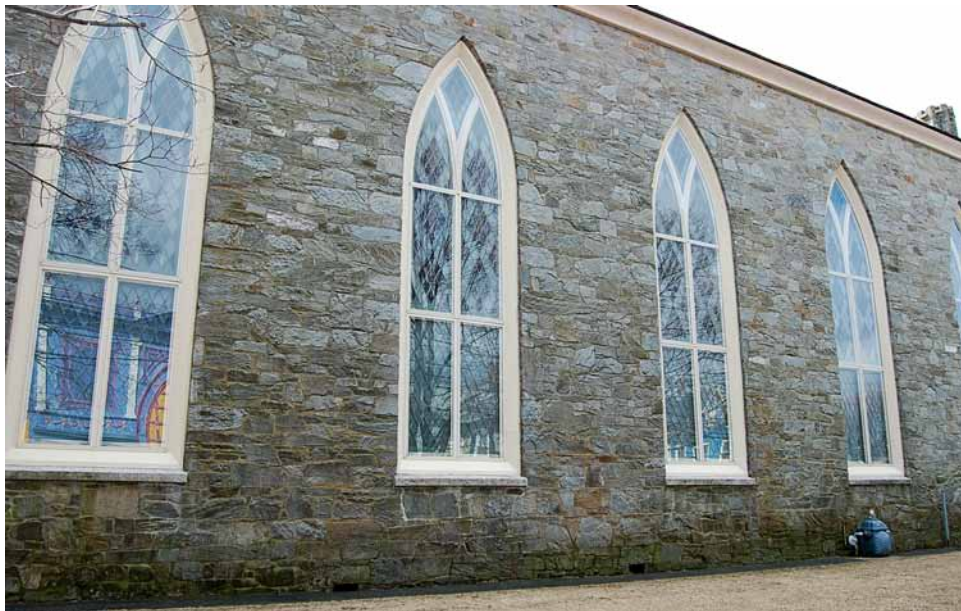

Reinstallation of Sash:

- **1.2.31** Install new brass weather stripping on jamb sides of upper and lower sashes. Also install brass weather stripping at meeting rail.
- **1.2.32** Provide spring bronze or copper weather stripping for window reinstallation. 204 inches by 1.125. 008” hemmed spring bronze (brass) packed with nails of similar material. Nails should be approximately 1-1/2” on center. Fills up to a 1/8” space in a closed position.
- **1.2.33** Acceptable manufacturer: Pemko Weatherization Products or equal. Pemko Manufacturing Company: 5535 Distribution Drive, Memphis TN 38141, 800-824-3018 <http://www.pemko.com>
- **1.2.34** Replacement sash rope: Provide new hemp rope of same size as existing original sash rope.
- **1.2.35** Replacement of sash chain: Provide new chain to match existing where missing.
- **1.2.36** Replacement of sash weights: Provide new weights in locations where existing weights are damaged or missing.
- **1.2.37** Acceptable manufacturer for items mentioned above: <http://www.smithrestorationsash.com/> or equal.
- **1.2.38** Reinstall sash in original location according to documentation.
- **1.2.39** All materials required for work in this section shall be subject to approval by the architect based on submittal of product information, samples and supporting material.⁵

08 52 69 Wood Storm Windows

1.1 Existing Conditions:

The storm windows are fabricated out of aluminum and are in good condition. Currently unventilated, they are causing moisture damage to the paint finish and windows. The owner would like to make existing windows operable, so the new storm windows must be able to open in conjunction with church windows—something the existing storm windows are unable to do.

The Baptist Church in Warren has 14 lancet-arched windows that are in fair condition, requiring some repair.

1.2 Rehabilitation Method:

Removal of Existing Storms Windows:

- **1.2.1** Carefully remove existing storm windows without damaging existing exterior detail. Dispose of aluminum responsibly.

New Storm Windows:

- **1.2.1.1** Provide storm windows with minimum visible frame made of wood or a paintable material. Storm window can be surface or in-jamb mounted depending on the existing window detail.
- **1.2.1.2** Acceptable manufacturer: <http://www.smithrestoration-sash.com/> or equal.
- **1.2.1.3** All materials and shop drawings required for work in this section shall be subject to approval by preservation consultant and the architect based on submittal of product information, samples and supporting material.⁶

04 00 00 Masonry

04 01 40.51 Stone Maintenance

1.1 Existing Conditions: The north elevation masonry looks intact and in good condition owing to the recent repointing. Of chief concern are the fracture lines around each windowsill. Although they may be no more than settling, their presence at several windows could indicate a larger structural concern.

1.2 Rehabilitation Methods:

- **1.2.1** Because the severity of the concern is not determined, the fractures should be continuously monitored to ensure that they are not spreading or creating visible problems.
- **1.2.2** If the cracks change either in width or length, a structural engineer should be consulted.

04 01 40.52 Stone Cleaning

2.1 North Elevation:

2.1.1 Existing Conditions: From grade to three feet high, the exterior stone wall on the

north elevation is covered in biological growth; this is caused by the inefficient shedding of water.

2.1.2 Rehabilitation Methods: The biological growth is a mold and should be treated with an ammonia solution.

- **2.1.2.1** A solution of one part ammonia to three parts water should be applied to the affected area.
- **2.1.2.2** Scrub the masonry with a natural bristle brush.
- **2.1.2.3** Repeat process as necessary.
- **2.1.2.4** Clean with water to remove any solution residue from the masonry when all biological growth has been removed.

3.2 West Elevation:

3.2.1 Existing Conditions: The masonry along the west elevation shows some staining of the stone. This is due to the bleeding of the rusted iron fittings that supports lighting along the rear of the church.

3.2.2 Rehabilitation Methods: Clean the masonry with a solution specifically for masonry staining from ferrous materials.

- **3.2.2.1** Prepare the area of masonry around the stain with a liquid strippable masking agent to prevent it being affected by the cleaning process.
- **3.2.2.2** Wet the area with water prior to treatment.
- **3.2.2.3** Work from the top down and apply a ferrous-based stain remover such as Sure Klean

Ferrous Stain Remover with a natural bristle brush.

- **3.2.2.4** Allow the remover to stand for three to five minutes before rinsing the area with pressurized cold water of no more than 300 psi. Repeat process as necessary.



West elevation shows some stone wall rust staining, which needs to be cleaned.

Rehabilitation Plan

Interior

Interior Plaster Rehabilitation Division 09: Finishes

09 01 20.91 Plaster Restoration

1.1 Existing Conditions:

Overall, the plaster is in good condition; however, there are a few sections that are deteriorating or cracking, especially in the northwest and northeast corners of the building. The chancel also has plaster issues due to the roof leak. There are no sections where the plaster is detaching from the substrate.

1.2 Rehabilitation Method:

- 1.2.1 Repairs throughout for small to large sized cracks.
- 1.2.2 Widen the crack slightly with a sharp, pointed tool.
- 1.2.3 Fill the crack. It may be necessary to bridge the crack with tape. In this instance, a fiberglass mesh tape is pressed into the patching material.

- 1.2.4 After the first application of a quick setting joint compound dries, use a second coat to cover the tape, feathering it at the edges. Apply a third coat to even out the surface, followed by light sanding. Clean off the area with a damp sponge then dry it to remove any leftover plaster residue or dust.



- 1.2.5 Acceptable plaster crack patching compound: Provide “Sheetrock All Purpose Joint Compound Ready Mixed” as manufactured by U.S. Gypsum Co., or approved equal made by DAP; apply per manufacturer recommendations.

- 1.2.6 All materials and shop drawings required for work in this section shall be subject to approval by preservation consultant and the architect based on submittal of product information, samples and supporting material.⁷

Decorative Paint Rehabilitation Division 09: Finishes

09 01 90.91 Paint Restoration

1.1 Existing Conditions

The decorative paint which accents the lancet arches throughout is in good condition. However, the paint on the lower portion of the lancet arch of the windows is deteriorating. The decorative paint in the chancel is in fair condition. The paint in the chancel has suffered moisture damage from a roof leak that has since been repaired. The damaged paint and plaster areas have not been repaired.



1. Areas of paint failure need to be scraped, sanded, cracks filled and surface painted to match existing paint.
2. Cracking and peeling of decorative paint, which needs to be filled and painted to match existing paint.

1.2 Rehabilitation Method

- 1.2.1 Onsite collection of paint samples and laboratory analysis of surface colors and treatments must be undertaken to assess appropriate paint material and colors. Historic paint formulation is not practical for this project.
- 1.2.2 Cleaning may be all that is needed for most of the paint surface. This can be done with warm water to clean off accumulated dirt.
- 1.2.3 Gentle hand scraping and sanding is advised to remove any loose paint or plaster.
- 1.2.4 Plaster surfaces should be made as smooth as they were historically so that the paint film will cover a relatively uniform surface.

- **1.2.5** Once the substrate and its surface are clean, free from crumbling, loose material or dust, the next step is to undercut and fill any cracks in plaster surfaces.
- **1.2.6** Apply matching paint with a natural or synthetic brush.
- **1.2.7** All materials and shop drawings required for work in this section shall be subject to approval by preservation consultant and the architect based on submittal of product information, samples and supporting material.⁸

Interior Woodwork Restoration Division 06: Wood, Plastics and Composites

06 01 40.91 Architectural Woodwork Restoration

1.1 Existing Conditions:

The finish to the wood paneling in the chancel has suffered damage due to the water leak; however, there is no noticeable damage to the structure of the wood. Overall, the wood in the chancel is in good condition.



1.2 Rehabilitation Methods:

- **1.2.1** Onsite collection of finish samples and laboratory analysis of surface treatments must be undertaken to assess appropriate finish, glazing material and stain color.
- **1.2.2** Sand areas where water damage has occurred to remove finish and expose bare wood. When the finish has been removed, bleach the entire stained surface with a solution of oxalic acid if wood is stained dark.⁹



- **1.2.3** Stain bare wood to match existing stain.
- **1.2.4** Prepare existing finish surrounding treated area with sandpaper grit-220.
- **1.2.5** Re-finish the wood paneling to match existing finish throughout.
- **1.2.6** All materials and shop drawings required for work in this section shall be subject to approval by preservation consultant and the architect based on submittal of product information, samples and supporting material.

Wood Graining Rehabilitation Division 09: Finishes

09 94 16 Faux Finishing

1.1 Existing Conditions:

The faux wood graining throughout the sanctuary can be found on doors, door casings, pews and wood paneling. On the mezzanine overlooking the sanctuary, the wood graining is applied on plaster to mimic wainscoting. There are sections of wood graining that are failing, especially in areas applied on the plaster.

1.2 Rehabilitation Method:

- **1.2.1** Onsite collection of finish samples and laboratory analysis of surface treatments must be undertaken to assess appropriate finish, glazing material and stain color.
- **1.2.2** Gentle hand scraping and sanding is advised to remove any loose finish or plaster substrate.
- **1.2.3** Plaster surfaces should be made as smooth as they were historically so that the faux wood graining will cover a relatively uniform surface.

1. Water damage to chancel woodwork requires repair.
2. Faux finished wood graining has worn away in some areas.

- **1.2.4** Once the substrate and its surface are clean, free from crumbling, loose material or dust, the next step is to undercut and fill any cracks in plaster surfaces
- **1.2.5** Apply wood graining to match existing grain patterns with appropriate brushes.
- **1.2.6** Apply protective finish.
- **1.2.7** All materials and shop drawings required for work in this section shall be subject to approval by preservation consultant and the architect based on submittal of product information, samples and supporting material.¹⁰

Interior Leaded Glass Rehabilitation Division 08: Openings

08 01 52.93 Historic Treatment of Wood Windows

1.1 Existing Conditions:

There is leaded glass throughout the sanctuary. The sagging of the lead came and glass is an indication that the structural integrity of the lead support is beginning to fail. The lead has not failed to the point of breaking or dislodging the glass.

1.2 Rehabilitation Method:

- **1.2.1** If window is sagging or bulging more than 1½” out of plane, it has reached the point where it should be removed from the opening to be flattened out.
- **1.2.2** Record location of each section prior to removal to ensure section is reinstalled in original location.



- **1.2.3** The window must be allowed to flatten over a few weeks in a horizontal position. This will minimize stress on the solder joints and glass. A moderate weight and controlled heat will help coax the window back into its original plane.
- **1.2.4** Once the window has flattened, additional support should be added as necessary. It is crucial to consider the original design so the new support bars do not intrude on important window features.
- **1.2.5** Reinstall windows.
- **1.2.6** All materials and shop drawings required for work in this section shall be subject to approval by preservation consultant and the architect based on submittal of product information, samples and supporting material.¹¹

The stained glass window in the door is bowing due to failure of the lead comes.

Canvas Ceiling Rehabilitation Division 09: Finishes

09 01 50.91 Ceiling Restoration

1.1 Existing Conditions:

Canvas ceiling in chancel area is in good condition; a few areas have detached due to water damage.

1.2 Rehabilitation Method:

- **1.2.1** Remove canvas ceiling in areas where canvas has detached.
- **1.2.2** Laboratory analysis of surface treatments must be undertaken to assess appropriate paint finish.

- **1.2.3** Assess condition of ceiling substrate, and determine if replacement is necessary to ensure proper re-installation of canvas.
- **1.2.4** Clean canvas of existing adhesive and substrate.
- **1.2.5** Repair canvas as necessary.
- **1.2.6** Reinstall canvas with appropriate water based adhesive.
- **1.2.7** Touch up or repaint canvas as necessary to match existing color.
- **1.2.8** All materials and shop drawings required for work in this section shall be subject to approval by preservation consultant and the architect based on submittal of product information, samples and supporting material.¹²

Sanctuary Floor Covering Division 09: Finishes

09 68 00 Carpeting

1.1 Existing Conditions:

The carpet in the main sanctuary is in need of replacement. Certain areas are heavily stained by water damage with sections worn through to the backing.

1.2 Rehabilitation Method:

- **1.2.1** Remove existing carpet.
- **1.2.2** Prepare subfloor for proper installation of new carpet.

- **1.2.3** Install new carpet in a direction that reduces the number of seams and material waste.
- **1.2.4** New carpeting used as an interior floor finish material shall comply with the radiant flux requirements of NFPA 101, Life Safety Code for new construction.¹³
- **1.2.5** All materials and shop drawings required for work in this section shall be subject to approval by preservation consultant and the architect based on submittal of product information, samples and supporting material.

Addition of Cry Room Division 13: Special Construction

1.1 Existing Conditions:

The church wishes to have a cry room installed. We are suggesting the installation of a modular or prefabricated room that could easily be broken down if necessary and does not significantly impact the fabric of the church interior.

1.2 Installation Method:

- **1.2.1** Acceptable manufacture for modular cry-room: <http://www.alliedmodular.com/gallery/> or equal
- **1.2.2** Provide enough lead-time for the fabrication of the modular room.



The puckering of the gold leafed, canvas ceiling in the vestry can be seen in the lower left corner.

- **1.2.3** Install per manufacture's instruction.
- **1.2.4** All materials and shop drawings required for work in this section shall be subject to approval by preservation consultant and the architect based on submittal of product information, samples and supporting material.

New Heating System Division 23: Heating, Ventilating and Air Conditioning

1.1 Existing Conditions:

The boiler that heats the church was installed in 1993. The boiler warms the basement but does not have the ductwork infrastructure to warm the sanctuary. Installation of new system is recommended.

1.2 Recommended Method:

- **1.2.1** Remove old system. Recommend new high efficiency natural gas boiler or furnace.
- **1.2.2** New furnace to utilize outside combustion air to reduce air drawn into the building through uncontrolled infiltration.
- **1.2.5** Replacement boiler installed in an existing building shall comply with access and egress requirements specified in the Rhode Island Boiler and Pressure Vessel Code, 1989 edition and/or the Mechanical Code SBC-4. (Boilers over 200,000 BTU require approval by the Department of Labor and Training.)¹⁴
- **1.2.6** Acceptable manufacturer: http://www.energystar.gov/index.cfm?c=boilers.pr_boilers http://www.energystar.gov/index.cfm?c=furnaces.pr_furnaces

- **1.2.7** All materials and shop drawings required for work in this section shall be subject to approval by preservation consultant and the architect based on submittal of product information, samples and supporting material.¹⁵

Handicap Stair Lift Division 14: Conveying Equipment

14 41 00 People Lifts

1.1 Existing Conditions:

The existing stair lift is in good condition and is regularly maintained. Parts for the lift are increasingly hard to come by, which may make the lift obsolete. Recommend replacing lift when no longer operable.

1.2. Recommended Method:

- **1.2.1** Continued care and maintenance of existing unit is recommended.

ADA Bathroom Rehabilitation

1.1. Existing Conditions:

The building is accessible by the northwest from the parking lot on Miller Street. The Main Street



stair from the basement to the sanctuary main floor is handicap accessible. The bathrooms are currently inaccessible. The current bathroom at the southwest corner of the church currently has two stalls and two steps to enter the lavatory. The church wishes to make this facility ADA compliant. To facilitate the installation of an ADA compliant bathroom, it is necessary to remove all partitions of current stalls, existing toilets, the sink and any wall fixtures.

Once demolished, the bathroom will be an empty space. The floor will be raised to create a flat entry into the room. All plumbing and systems can be located beneath this platform. The room itself will be a single stall with the toilet installed at the southwest corner of the room, grab-rails at the south and west walls. The sink will be installed along the north wall in order not to block the entry or impede the necessary area around the toilet (60 x 59"). All changes must abide by State of Rhode Island and Providence Plantations Rehabilitation Code for existing buildings and structures – Chapter 10 Accessibility – and the Town of Warren Department of Building and Zoning. Accessibility must meet the 2010 ADA Standards for Accessible Design.

The southwest bathroom facility will be made ADA compliant.

Division 02: Existing Conditions

02 41 91 Selective Historic Demolition

1.2. Rehabilitation Method:

- **1.2.1** Demolish proper right side of entry to widen entrance into bathroom.
- **1.2.2** Doorway at least 32" wide to clear. Doors equipped with accessible handles, operable at 48" high or less. Replace inaccessible knobs or latches with lever or loop. Doors to be opened easily: five pounds maximum force.



- **1.2.3** Removal of obstructing furniture, providing accessible signage, widening of toilet stalls and installation of grab bars as necessary.
- **1.2.4** Wheelchair access needs to be 36" of clear width for forward movement, and a five-foot diameter clear space or a T-shaped space to make turns. A minimum distance of 48", clear of the door swing, is needed between the two doors of an entry vestibule.
- **1.2.5** There must be a 36"-wide path to all fixtures.
- **1.2.6** Add grab bars no higher than 48".
- **1.2.7** Toilet seat must be 17" to 19" high.
- **1.2.8** Lavatory must have a 30"-wide by 48"-deep clear space in front. A maximum of 19" of the required depth may be under the lavatory. Lavatory rim no higher than 34". Must be at least 29" from the floor to the bottom of the lavatory apron (excluding pipes).
- **1.2.9** Faucet must be operated with one closed fist.
- **1.2.10** Soap and other dispensers and hand dryers must be 48" high.
- **1.2.11** Mirror must be mounted with the bottom edge of the reflecting surface 40" high or lower.
- **1.2.12** Water conservation: When any water closet, urinal, lavatory faucet, kitchen faucet or shower head is replaced, the replacement

fixture shall comply with the water conservation requirements specified in Table 604.4 of the International Plumbing Code, 2000.¹⁶

- **1.2.13** All materials and shop drawings required for work in this section shall be subject to approval by preservation consultant and the architect based on submittal of product information, samples and supporting material.¹⁷

Division 06: Wood, Plastics and Composites

06 10 53 Miscellaneous Rough Carpentry

1.1 Existing Conditions:

The bathroom floor must be raised for the bathroom to become accessible.

1.2 Rehabilitation Method:

- **1.2.1** Install a raised platform to meet the existing grade of floor when entering the bathroom.
- **1.2.2** All materials and shop drawings required for work in this section shall be subject to approval by preservation consultant and the architect based on submittal of product information, samples and supporting material.

Tower Stair Division 06: Wood, Plastics and Composites

06 10 53 Miscellaneous Rough Carpentry

1.1 Existing Conditions:

The tower stair does not currently meet code. According to the State of Rhode Island and Providence Plantations Rehabilitation Code for existing buildings and structures, historically significant stairways shall be accepted without complying with the handrail and guardrail requirements. Existing handrails and guards shall be permitted to remain provided they are not structurally dangerous. Stairway railings may be reconstructed with handrails matching the original handrails.¹⁸

1.2 Rehabilitation Method:

- **1.2.1** Recommend adding an additional handrail above existing highest rail to meet current code of 36" or 42" if rail above 5'10".
- **1.2.2** All materials and shop drawings required for work in this section shall be subject to approval by preservation consultant and the architect based on submittal of product information, samples and supporting material.

The bell tower from the first floor; the stair does not meet code.

Cast Iron Fence Rehabilitation Division 32: Exterior Improvements

32 31 19 Decorative Metal Fences and Gates

1.1 Existing Conditions:

Skirting the perimeter of the church property on Main Street and Miller Street is a decorative cast iron fence and looks to be original based on historic photos, with about 75% of the original material still existing. Some missing pieces of the



original fence have been replaced with similar pieces that do not detract from the overall aesthetic of the fence, except for some issues with the protective finish. There are still some missing and broken pickets, and many of the footings are heaved. Overall the fence is in fair condition.

1.2 Rehabilitation Plan: Maintain and protect finish.

- **1.2.1** When there is extensive failure of the protective coating and/or when heavy corrosion exists, the rust and most or all of the paint must be removed to prepare the surfaces for new protective coatings
- **1.2.3** Local environmental regulations may restrict the options for cleaning and paint removal methods, as well as the disposal of materials.
- **1.2.4** Hand scraping, chipping and wire brushing are the most common and least expensive methods of removing paint and light rust from cast iron.
- **1.2.5** Before removing paint from historic architectural cast iron, a microscopic analysis of samples of the historic paint sequencing is recommended.
- **1.2.6** Thorough surface preparation is necessary for the adhesion of new protective coatings. All loose, flaking and deteriorated paint must be removed from the iron, as

well as dirt and mud, water-soluble salts, oil and grease. Old paint that is tightly adhered may be left on the surface of the iron if it is compatible with the proposed coatings. The retention of old paint also preserves the historic paint sequence of the building and avoids the hazards of removal and disposal of old lead paint.

- **1.2.7** Joints between pieces must be caulked to prevent water from seeping in and causing rusting from the inside out. For good adhesion and performance, an architectural-grade polyurethane sealant or traditional white lead paste is preferred.¹⁹
- **1.2.8** Although the footings are heaved, removal from the granite foundation would potentially damage the existing fence. The missing pickets should be replaced with replicas as has been done in prior incidents of replacements
- **1.2.9** All materials and shop drawings required for work in this section shall be subject to approval by preservation consultant and the architect based on submittal of product information, samples and supporting material.

Citations

1. <http://www.nps.gov/TPS/how-to-preserve/briefs/29-slate-roofs.htm>
2. <http://www.gsa.gov/portal/content/112054>

3. <http://www.alpinesnowguards.com/our-products>
4. <http://www.nps.gov/TPS/how-to-preserve/briefs/10-paint-problems.htm>
5. <http://www.nps.gov/TPS/how-to-preserve/briefs/9-wooden-windows.htm>
6. <http://www.gsa.gov/portal/content/113194>
7. <http://www.nps.gov/TPS/how-to-preserve/briefs/21-flat-plaster.htm>
8. <http://www.nps.gov/TPS/how-to-preserve/briefs/28-painting-interiors.htm>
9. http://www.nytimes.com/2009/05/28/garden/28fix.html?_r=0
10. <http://www.nps.gov/TPS/how-to-preserve/briefs/28-painting-interiors.htm>
11. <http://www.nps.gov/TPS/how-to-preserve/briefs/33-stained-leaded-glass.htm>
12. <http://www.nps.gov/TPS/how-to-preserve/briefs/21-flat-plaster.htm>
13. <http://www.carpet-rug.org/commercial-customers/specification-and-installation/>
14. <http://www.rbfc.ri.gov/>
15. <http://www.mipandl.org/>
16. <http://www.rbfc.ri.gov/>
17. <http://www.nps.gov/TPS/how-to-preserve/briefs/32-accessibility.htm>
18. http://www.rbfc.ri.gov/rehab/chapter_9.php
19. <http://www.nps.gov/TPS/how-to-preserve/briefs/27-cast-iron.htm>

The cast iron fence is original to the church with about 75% of the original material still existing.

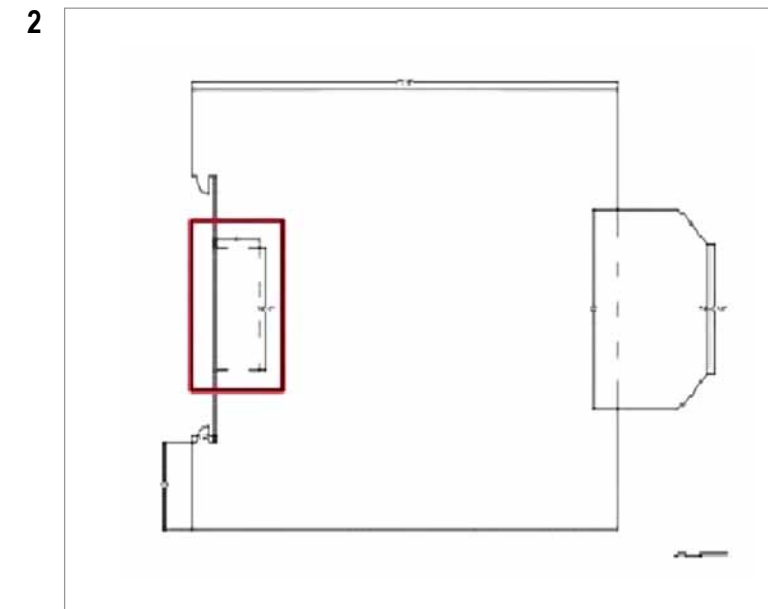
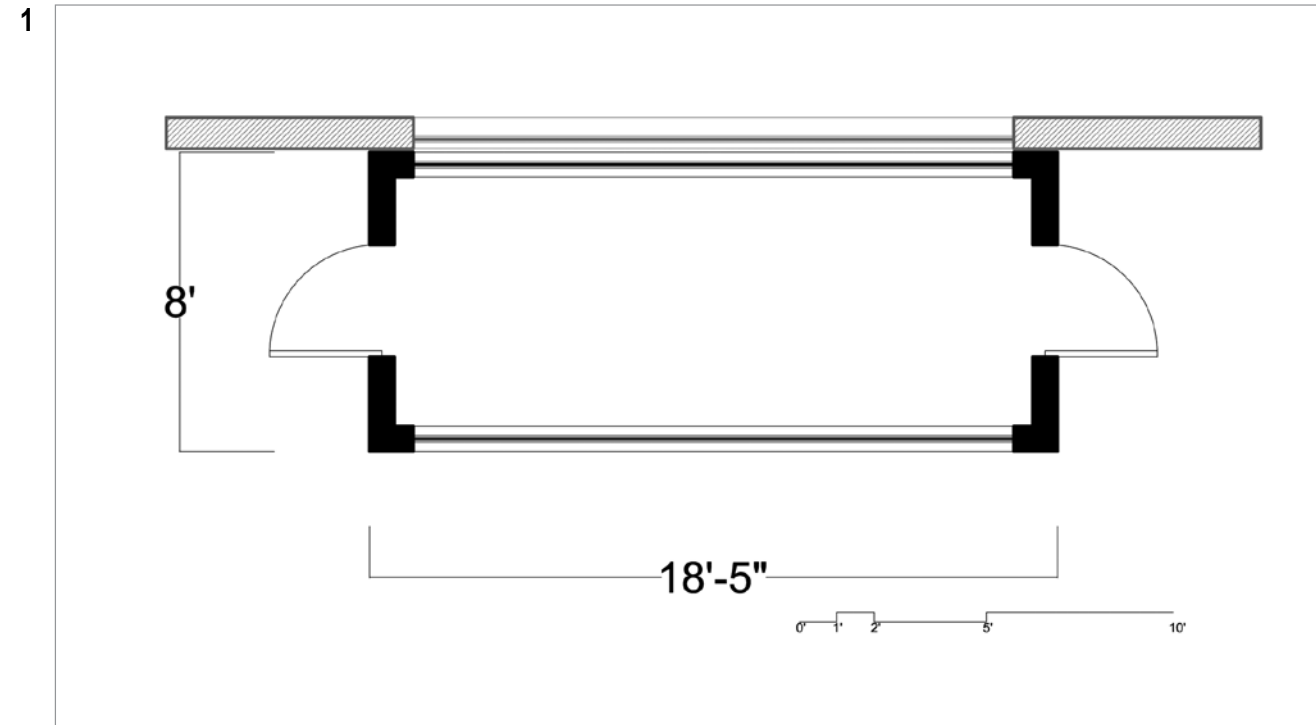

1,2. Design and location of a new addition for a cry room. The modular or prefabricated room could easily be broken down if necessary.

3. Existing and revised ADA-compliant bathroom design.

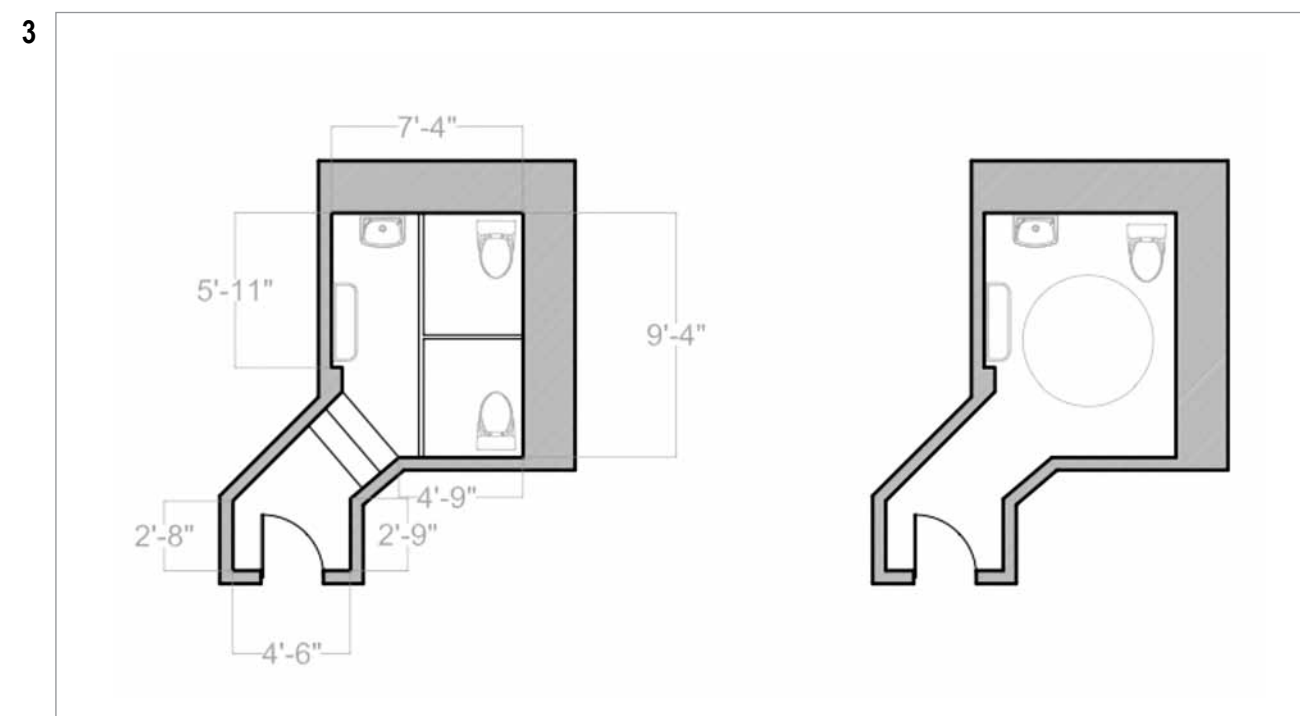



Front doors of The Baptist Church in Warren.

Conclusion

The Baptist Church in Warren is in good condition for a building of its age and size. There were many program needs brought to the table, and they have been listed in the order of importance. With the Master Rehabilitation Plan, the Church can now begin rehabilitating their worship space. It is recommended that the following five items be cared for first:

1. Address window concerns
2. ADA-compliant bathroom
3. Sanctuary heating
4. Cry room addition
5. Maintenance of faux finishes and paint finishes

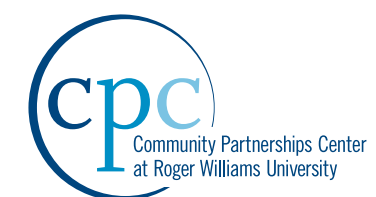

Roger Williams University
One Old Ferry Road
Bristol, Rhode Island 02809

cpc@rwu.edu
<http://cpc.rwu.edu>